



152nd NYYC ANNUAL REGATTA

Presented by ROLEX

June 9-11, 2006

Newport, Rhode Island

NOTICE OF RACE

(incorporating Amendment #1 dated March 20, 2006 and Amendment #2 dated March 31, 2006)

The Organizing Authority (OA) is the New York Yacht Club (NYYC).

GENERAL FORMAT

The 152nd NYYC Annual Regatta will consist of several overlapping series. Yachts may enter one of the series described below for which they are eligible:

- A **THREE-DAY Series** on Friday, Saturday and Sunday, June 9-11, is for one-design classes by invitation. This may include a buoy race(s) followed by an Around-the-Island(s) Race on Friday, and buoy races on Saturday and Sunday. All races will count in the overall series.
- A **TWO-DAY Series** on Saturday and Sunday, June 10-11, is open to any eligible yacht not entered in the one-design Three-Day Series. Yachts that have entered in the ONION PATCH SERIES will race as part of the Two-Day Series. This Series will consist of buoy races on Saturday and Sunday.

In addition, yachts entered in the Two-Day Series may enter the **AROUND-THE-ISLAND(S) Race** on Friday, June 9. This race will be scored separately from the Two-Day Series described above.

1 RULES

- 1.1 The regatta will be governed by the rules as defined in *The Racing Rules of Sailing* (RRS). Appendix D, Team Racing Rules, will not apply.
- 1.2 **Regatta Regulations:** The Regatta Regulations will apply and are included as Attachment A to this Notice of Race, as well as posted on the Annual Regatta website at www.nyyc.org.
- 1.3 The prescriptions of US SAILING, except Appendix Q, will apply and are included as Attachment B to this Notice of Race, as well as posted on the Annual Regatta website at www.nyyc.org.
- 1.4 **Offshore Special Regulations:** Minimally all yachts shall comply with the 2006-2007 ISAF Offshore Special Regulations, Category 5 (posted at www.nyyc.org) and shall comply with their class rules, where applicable. Yachts that are not normally rigged with lifelines are exempt from Regulation 3.14. In the event of a conflict between these regulations and applicable class rules, the class rules shall apply. The US SAILING prescriptions to the Offshore Special Regulations shall apply except the requirement to wear personal flotation while starting and finishing.
- 1.5 The sailing instructions may describe rules or changes to class rules that will apply to specific classes.
- 1.6 The protest committee may impose suitable penalties, other than disqualification, for violations of the ISAF Offshore Special Regulations or other non-Part 2 rules. This changes RRS 64.1.

2 ADVERTISING

- 2.1 For the purposes of RRS 79 and ISAF Regulation 20, Advertising Code, Category C will apply.
- 2.2 All yachts shall display the provided Rolex bow stickers and Rolex backstay flag while racing.

3 ELIGIBILITY AND ENTRY

- 3.1 Entry is open to yachts with a minimum LOA of 25 feet who satisfy one or more of the following entry requirements (see 3.2 – 3.7). The OA reserves the right to limit the number of entries in any class.
- 3.2 **IRC Yachts (Spinnaker):** Entry is open to all yachts with a valid 2006 IRC certificate. Yachts with an IRC rating of 1.08 or higher must have an endorsed IRC certificate. The OA, at its discretion, may waive the 1.08 rating requirement for endorsement. Weight limits will apply and are listed in the Regatta Regulations.
- 3.3 **PHRF Yachts:** Entry is open to all yachts with a valid 2006 PHRF of Narragansett Bay certificate rating between 91 and 135. Weight limits and crew limits will apply and are listed in the Regatta Regulations. Yachts from other PHRF areas must obtain a PHRF certificate from PHRF-NB at <http://www.phrf-nb.org/>
- 3.4 **NYYC Cruising Rule (non-spinnaker):** Entry is open to all yachts with a valid 2006 NYYC CR certificate. Applications for a 2006 NYYC CR rating can be found at www.nyyc.org.
- 3.5 **Classic Yachts (non-spinnaker):** Entries are open to all Vintage and Classic yachts built or designed prior to 1965 made of wood or steel, and using traditional building methods and rigged with only aluminum or wooden spars. Only traditionally constructed sails are permitted; they shall be of woven canvas, nylon, or polyester (Dacron) only. Sails made using laminate or composite construction or materials (such as, but not limited to, Mylar, Kevlar, Spectra, Carbon Fiber, etc.), including those sails utilizing advanced shaping technologies (3DL or similar) are not permitted. All yachts must hold a valid 2006 CRF rating. Applications for a 2006 CRF rating can be found at www.nyyc.org.
- 3.6 **12 Metre Yachts:** Entries are open to all 12 Metre yachts holding a valid 2006 class certificate (minimum of six entries).
- 3.7 **One-Design Yachts:** Entries are open to all classes with a minimum of eight entries which meet the LOA minimum of 25 feet including: Farr 40, Farr 395, Beneteau First 36.7, J/109, Melges 32, J/44, Swan 45, J/80, J/105, J/35, J/120 and other eligible one-design classes as may be determined. Entrants must meet all ownership, class membership (including crew eligibility requirements), sail measurement and crew weigh-in requirements as may be required by their class.
- 3.8 **Entry Forms:** Entry forms will be available on the NYYC website (www.nyyc.org). An official entry form including an executed liability waiver and entry fee must be submitted on line on or before Monday, June 5, 2006 at 1700.
- 3.9 **Check-in:** All yachts shall pick up their packets at check-in. Check-in will take place in the Carriage House of NYYC, Harbour Court; 5 Halidon Avenue; Newport, RI 02840.
- 3.10 **Onion Patch:** Entry for the Onion Patch Series shall be made on line at www.onionpatchseries.com and submitted on or before June 8, 2006.
- 3.11 **Team Entries:** The Great Corinthian and The Rolex Cup Team entries shall be made on the NYYC website (www.nyyc.org) and shall be submitted on line on or before Monday, June 5, 2006 at 1700.
- 3.12 **Liability Waivers:** Any supplemental entry forms, including crew liability waivers and crew lists, will be available on the NYYC website (www.nyyc.org) and submitted, where required, at check-in before racing.

7 MEASUREMENT

- 7.1 Each yacht shall submit a valid certificate to the NYYC Sailing Office before Monday, June 5 at 1700.
 - 7.1.1 12 Metres shall submit a copy of their valid 2006 class certificate.
 - 7.1.2 One-design yachts shall submit a copy of their valid class measurement certificate when one is required by their class rules.
 - 7.1.3 PHRF yachts shall submit a copy of their valid 2006 PHRF-NB certificate.
 - 7.1.4 IRC yachts shall submit a copy of their valid 2006 IRC certificate.
 - 7.1.5 NYYC CR yachts shall have a valid 2006 NYYC CR rating on file with the Sailing Office.
 - 7.1.6 Classic Yachts shall have a 2006 CRF certificate.
- 7.2 Yachts, including all qualifying equipment and sails, may be subject to random inspection at any time during this event.

8 SAILING INSTRUCTIONS AND CLASS ASSIGNMENTS

Sailing instructions for the 152nd NYYC Annual Regatta will be available on the NYYC website no later than May 26, 2006. Class assignments and scratch sheets will be available at check-in and on the NYYC website (www.nyyc.org).

9 VENUE

Races will be held off Newport, RI on Rhode Island Sound or on Narragansett Bay.

10 COURSES

Courses for all classes will be defined in the sailing instructions. The diagrams in Attachment C show the buoy courses.

11 PENALTY SYSTEM

- 11.1 The Scoring Penalty, RRS 44.3, will apply; however, the sailing instructions may change this for specific one-design classes.
- 11.2 There will be both an international jury and a protest committee. The decision of the jury will be final as provided in rule 70.4. The jury will hear all protests in the Onion Patch Series and other protests from the Annual Regatta when the jury is available.

12 SCORING

- 12.1 Up to seven races will be run in the Two-Day Series including the Onion Patch Series. One race is required to be completed to constitute a series.
- 12.2 A yacht's series score will be the total of all of her race scores. The Around-the-Island(s) Race will only count in the scores of yachts participating in the Three-Day Series.
- 12.3 The 152nd NYYC Annual Regatta Around-the-Island(s) Race Team Trophy for the Rolex Cup will be scored by using each team member yacht's percentage points (finish points divided by the number of starters) within its respective class. The lowest average team score will win.
- 12.4 The Great Corinthian Trophy will be scored by calculating the average of each team member yacht's percentage points in each race (finish points divided by the number of starters) within its respective class. The points accumulated by each team shall be divided by the number of yachts comprising the team. The lowest score wins.
- 12.5 The IRC classes will be scored using the IRC Time Corrector (TCC) using time on time scoring.
- 12.6 PHRF classes will be scored using time on distance.
- 12.7 Classic Yachts will be scored using CRF.

13 PRIZES

- 13.1 152nd NYYC Annual Regatta Around-the-Island(s) Race class prizes will be presented at the Awards Party after the race on Friday, June 9 at Harbour Court. Prizes will be awarded to the winning yacht in each class. Second and third place prizes may also be awarded.
- 13.2 152nd NYYC Annual Regatta prizes will be presented at the NYYC Awards Dinner in New York City on November 9, 2006, to which winners will be invited. Prizes will be awarded to the winning yacht in each class. Second and third place prizes may also be awarded.
- 13.3 The Rolex Cup will be awarded to the best two-yacht team in the Around-the-Island(s) Race.
- 13.4 The Great Corinthian Trophy will be presented to the yacht club team with the best score in the Annual Regatta.
- 13.5 The Solution Trophy may be awarded to the yacht enrolled in the New York Yacht Club, which, in the opinion of the Race Committee, makes an outstanding performance overall in the Regatta.

14 LIABILITY

- 14.1 Crew Waiver Form - As a condition of entry, each owner, skipper and individual participating crew member shall sign a liability waiver/media release and the fully executed Crew Waiver Form shall be submitted by fax (401-846-3303) or at check-in prior to racing. The Crew Waiver Form can be found at www.nyyc.org.
- 14.2 Competitors participate in the regatta entirely at their own risk. See RRS 4, Decision to Race. The Organizing Authority, Rolex Watch U.S.A. and affiliated companies, and other sponsors will not accept any liability for material damage or personal injury or death sustained in conjunction with or prior to, during, or after the regatta. Attention is also drawn to ISAF Offshore Special Regulation 1.02, Responsibility of the Person in Charge, as well as the "Waiver and Release of Liability" as stated on the entry form.

15 FURTHER INFORMATION

For further information, please visit our website at www.nyyc.org or contact the Sailing Office.
New York Yacht Club, Harbour Court; 5 Halidon Avenue; Newport, RI 02840
Tel: 401/845-9633; Fax: 401/846-3303; Email: sailingoffice@nyyc.org

152nd New York Yacht Club Annual Regatta

Presented By



152nd NYYC ANNUAL REGATTA

Attachment A - Regatta Regulations

1 REQUIRED EQUIPMENT

Each yacht shall carry a VHF radio capable of communicating with the race committee.

2 MINIMUM CREW

The minimum crew aboard while racing shall be four.

3 CREW CHANGES

Yachts shall sail with the same crew in all races, unless (i) permitted by applicable class rules, or (ii) a written request for crew change has been submitted on the form, available online and at the regatta desk, and approved in advance by the Race Committee. Any new crew must submit their crew waiver found at www.nyyc.org to the regatta desk in person or by fax at (401) 846-3303 prior to racing.

4 CREW WEIGH-INS

- 4.1 Crew weigh-ins will be conducted only if (i) required by applicable class rules, or (ii) a yacht has been protested for violation of the applicable crew weight limitation.
- 4.2 The official scale will be available in the Carriage House of NYYC at times posted on the Official Notice Board for yachts wishing to confirm their compliance with applicable crew weight limitations.

5 IRC REGULATIONS

The crew number for IRC yachts shall be as stated in the 2006 IRC Rule 27.4 shown below and apply only to those yachts required to hold an endorsed IRC certificate. There is no restriction on crew weight.

27.4 Crew Number/Weight

- 27.4.1 *There is no limitation on crew numbers or weight under IRC except for one designs and in races requiring boats to hold an 'Endorsed' certificate (see Rule 9.4). Attention is drawn to Rule 3.4.*
- 27.4.2 *Boats rated as one-designs, as noted on the boat's certificate, shall conform with their one-design class rules unless freed from this requirement by notice of race or sailing instructions.*
- 27.4.3 *In races requiring boats to hold 'Endorsed' certificates, the crew number printed on each boat's certificates shall not be exceeded.*
- 27.4.4 *In all other cases, the crew number printed on each boat's certificate is for information only, has no effect on TCC, and has no relevance under these Rules unless invoked by notice of race and/or sailing instructions. Crew number may be amended by notice of race or sailing instructions.*
- 27.4.5 *Race committees may invoke crew limitations, by number or by weight, in the notice of race and/or sailing instructions.*

6 PHRF REGULATIONS

6.1 Maximum Crew Weight and Crew Limitations

<u>Up to LOA (ft)</u>	<u>Weight Limit (lbs)</u>	<u>Max. Crew</u>
24.00	900	5
27.00	1080	6
30.00	1260	7
33.00	1440	8
35.00	1620	9
38.00	1800	10
40.00	1980	11
43.00	2160	12
45.00	2340	13
50.00	2520	14
55.00+	add 180 lbs. and 1 crew for each 5 feet of LOA over 50 feet	

A yacht's LOA is to be rounded to the nearest foot. For example, a 29.49-foot yacht is rounded to 29.00 feet LOA and is allowed a maximum crew weight of 1080 pounds and a maximum crew of 6 persons. A 29.50-foot yacht is rounded to 30.00 feet LOA and is allowed a maximum crew weight of 1260 pounds and a maximum crew of 7 persons.

- 6.2 PHRF entrants shall present a PHRF handicap certificate issued by PHRF Narragansett Bay. Applications and certificates may be obtained from PHRF-NB by contacting them via:

Website: www.phrf-nb.org

Email: PHRFAdmin@phrf-nb.org

Phone: (401) 253-0207 (Voice); (401) 254-1495 (Fax)

Address: PHRF-NB; P.O. Box 73; Bristol, RI 02809-0073

152nd NYYC ANNUAL REGATTA
Attachment B – US SAILING Prescriptions

INTRODUCTION After 'Changes to the Rules' add

US SAILING prescriptions are printed in bold italics except Appendices F and Q.

EQUAL OPPORTUNITY After Sportsmanship and the Rules add

Equal Opportunity

As the national authority for the sport of sailing in the United States of America, the United States Sailing Association is committed to providing an equal opportunity to all sailors to participate in the sport of sailing.

Rule 34 Change rule 34 title to: **MARK MISSING; RACE COMMITTEE ABSENT**

After rule 34 add

US SAILING prescribes that, if a finishing mark is missing but another one remains in place, a boat shall finish as close to the remaining mark as practicable on a line extending from its required side at a 90° angle to the last leg. If a boat finishes when the race committee is absent, to be scored as finishing she shall note her finishing time and her finishing position in relation to any nearby boats and report them to the race committee as soon as reasonably possible.

Rule 40 Change rule 40 title to: **PERSONAL BUOYANCY; HARNESSSES; LIFE-SAVING EQUIPMENT**

After rule 40.1 add

US SAILING prescribes that every boat shall carry life-saving equipment conforming to government regulations.

Rule 48 After rule 48 add

US SAILING prescribes that the use of additional special purpose lights such as masthead, spreader and jib-luff lights shall not constitute a breach of this rule.

Rule 55 Add rule 55

55 **FLAGS**

US SAILING prescribes that a boat shall not display flags except for signaling. A boat shall not be penalized for breaking this rule without prior warning and opportunity to make correction.

Rule 61.4 Add rule 61.4

61.4 **Fees for Protests and Requests for Redress**

US SAILING prescribes that no fees shall be charged for protests or requests for redress.

Rule 64.3 (b) After rule 64.3(b) add

US SAILING prescribes that the authority responsible for interpreting the rules of a handicap or rating system is the organization that issued the handicap or the rating certificate involved.

Rule 68 After rule 68 add

US SAILING prescribes that:

- (a) *A boat that retires from a race or accepts a penalty does not, by that action alone, admit liability for damages.*
- (b) *A protest committee shall find facts and make decisions only in compliance with the*

rules. No protest committee or US SAILING appeal authority shall adjudicate any claim for damages. Such a claim is subject to the jurisdiction of the courts.

- (c) **A basic purpose of the rules is to prevent contact between boats. By participating in an event governed by the rules, a boat agrees that responsibility for damages arising from any breach of the rules shall be based on fault as determined by application of the rules, and that she shall not be governed by the legal doctrine of ‘assumption of risk’ for monetary damages resulting from contact with other boats.**

Rule 75.3 Add rule 75.3

- 75.3** *US SAILING prescribes that the organizing authority shall not require a competitor to assume any liabilities of the organizing authority, race committee, protest committee, host club, sponsors, or any other organization or official involved with the event. (This is commonly referred to as an ‘indemnification’ or ‘hold harmless’ agreement.)*

Rule 76.1 After rule 76.1 add

US SAILING prescribes that an organizing authority or race committee shall not reject or cancel the entry of a boat or exclude a competitor eligible under the notice of race and sailing instructions for an arbitrary or capricious reason or for reason of race, color, religion, national origin, gender, sexual orientation, or age.

Rule 76.3 Add rule 76.3

- 76.3** *US SAILING prescribes that a boat whose entry is rejected or cancelled or a competitor who is excluded from a race or series shall be, upon written request, entitled to a hearing conducted by the protest committee under rules 63.2, 63.3, 63.4 and 63.6.*

Rule 87 After rule 87 add

US SAILING prescribes that sailing instructions shall not change or delete rules 61.4 or 76.3, Appendix F, or its prescriptions to rules 40.1, 68 or 76.1. However, for an international event the prescription to rule 40.1 may be deleted.

Rule 86.3 After rule 86.3 add

US SAILING prescribes that proposed rules may be tested, but only in local races.

Appendix A At the end add the following note:

***US SAILING Note:** The scoring systems in Appendix A may be inappropriate for a long series, such as a club's season championship held over several weeks or months, in which some boats do not compete in all of the races and in which more boats compete in some races than in others. ‘Scoring a Long Series’ on the US SAILING website (www.ussailing.org) provides an explanation of the scoring problems that occur in such series, alternative scoring systems, and language for sailing instructions to implement them.*

Appendix F Replace ISAF Appendix F with new **Appendix F** [see Appendix F below]

Appendix G After rule G2 add

US SAILING prescribes that unless otherwise stated in her class rules, the sails of a boat that is not in an ISAF International Class or Recognized Class shall comply with rule G1. However, offshore racing boats not in a class that is subject to rule G1 shall carry numbers allotted by US SAILING on mainsails, spinnakers and each overlapping headsail having a luff-perpendicular measurement exceeding 130% of the base of the foretriangle. This rule applies only to a boat whose owner’s national authority is US SAILING. The Sail Numbering System for offshore racing boats in the United States and an application for a sail number are available on the US SAILING website (www.ussailing.org).

Appendix L At the end of the preamble to Appendix L add

US SAILING Note: A guide to simplified sailing instructions suitable for events such as club or local regattas can be found on the US SAILING website (www.ussailing.org).

Appendix L Add a new Instruction 12.3 (with no marginal note) in Appendix L in bold italics as follows:

12.3 If the race committee intends to start another race on the same day, it will display the Second Substitute (with no sound) while boats are finishing.

Appendix Q After Appendix P add new **Appendix Q** [see Appendix Q below].

Protest Form Replace the ISAF Protest Form with the US SAILING Protest Form.

INDEX At end of introductory paragraph add

US SAILING prescriptions are not included in the Index.

APPENDIX F – APPEALS PROCEDURES

This appendix is a US SAILING prescription.

See rules 70 and 71. This appendix replaces Appendix F as adopted by the International Sailing Federation. The US SAILING Appeals Committee acts as the national authority within the meaning of rules 70.1 and 71.

F1 WHERE TO FILE AN APPEAL OR REQUEST

F1.1 Except as provided in rule F1.3, an appeal of a decision of a protest committee or a request by a protest committee for confirmation or correction of its decision shall be sent to the Race Administration Director at US SAILING (Box 1260, Portsmouth, RI 02871), who will forward it to the association appeals committee for the place in which the event was held. However, an appeal or request arising from an event run under the procedural rules of either the Intercollegiate Sailing Association or the Interscholastic Sailing Association will be forwarded to the association appeals committee for the ICSA and ISSA. US SAILING charges no fee for forwarding an appeal. However, the association appeals committee may require that a fee be paid before an appeal or request will be considered.

F1.2 Appeals of decisions of an association appeals committee, requests by an association appeals committee for confirmation or correction of its decisions, and all requests for interpretations of *rules* shall be made to the US SAILING Appeals Committee.

F1.3 Appeals of decisions of a protest committee acting under rule 69.1, appeals of decisions of a protest committee of a US SAILING national championship, and requests by such committees for confirmation or correction of their decisions shall be made to the US SAILING Appeals Committee.

F2 TO APPEAL OR MAKE A REQUEST

F2.1 To appeal the decision of a protest committee or association appeals committee a *party* to the hearing shall, within 15 days of receiving the written decision being appealed or a protest committee's decision not to reopen a hearing, send an appeal and a copy of the decision to the US SAILING Race Administration Director. The appeal shall state why the appellant believes the committee's decision or its procedures were incorrect. If an appeals fee is required it must be received before the appeal will be considered. The fee for appeals to US SAILING is \$25 for an appellant who is a member of US SAILING or another national authority and \$75 for all others.

F2.2 The appellant shall also send, with the appeal or as soon as possible thereafter, all of the following documents that are available to her:

- (a) the written *protest(s)* or request(s) for redress;
- (b) if the appeal is from a decision of an association appeals committee, the written decision of the protest committee;
- (c) a diagram, prepared or endorsed by the protest committee, showing the positions and tracks of all boats involved, the course to the next *mark* and its required side, the speed and direction of the wind,

- and, if relevant, the depth of the water and the speed and direction of any current;
- (d) the notice of race, sailing instructions, any other conditions governing the event, and any changes to them;
 - (e) any additional relevant documents; and
 - (f) the names and addresses of all *parties* and the protest committee chairman.

F2.3 To request confirmation or correction of its decision, a protest committee or association appeals committee shall send to the US SAILING Race Administration Director a copy of its decision and all relevant documents and comments. There is no fee for requests for confirmation or correction made to US SAILING.

F2.4 To request an interpretation of the *rules*, a club or other organization affiliated to US SAILING shall send to the US SAILING Race Administration Director its request, which shall include assumed facts. The fee for requests for interpretation of the *rules* is \$25. A US SAILING committee is considered to be an organization affiliated to US SAILING but need not pay the fee.

F3 NOTIFICATION OF THE COMMITTEE WHOSE DECISION IS BEING APPEALED

Upon receipt of an appeal, the appeals committee shall send a copy of the appeal to the committee whose decision is being appealed, asking it for any documents required by rule F2.2 not supplied by the appellant.

F4 COMMITTEE RESPONSIBILITIES

F4.1 Protest Committee

A protest committee whose decision is being appealed shall supply the documents requested under rule F3 and any facts or other information requested under rule F5. If directed to do so by the appeals committee, it shall conduct a hearing, or reopen the hearing, of the *protest* or request for redress, or conduct a hearing to consider redress.

F4.2 Association Appeals Committee

- (a) The association appeals committee shall send to all *parties*, and to the committee whose decision is being appealed or reviewed, copies of all relevant documents and comments it has received, except those supplied by that *party* or committee.
- (b) An association appeals committee shall consider an appeal it has refused to decide if directed to do so by the US SAILING Appeals Committee.

F4.3 US SAILING Appeals Committee

The US SAILING Appeals Committee shall send to all *parties*, to the protest committee and to the association appeals committee whose decision is being appealed or reviewed, copies of all relevant documents and comments it has received, except those supplied by that *party* or committee.

F5 INADEQUATE FACTS; REOPENING

An appeals committee shall accept the protest committee's finding of facts except when it decides they are inadequate. In that case it shall require the protest committee to provide additional facts or other information, or to reopen the hearing and report any new finding of facts, and the protest committee shall promptly do so.

F6 COMMENTS

The *parties*, the protest committee and, if relevant, the association appeals committee may make comments on the appeal or request or on any of the documents listed in rule F2.2. Comments shall be sent in writing to the appeals committee, with a copy to the other *parties* and committees involved, within 15 days after the *party* or committee received the document. The appeals committee need not consider comments sent after that time.

F7 OTHER PROVISIONS

In addition to the provisions of rule 71:

- (a) An association appeals committee acting under the rules of this appendix may take any of the actions permitted by the national authority in rules 71.2 and 71.3, subject to further appeal as provided in rule F1.2.
- (b) An appeals committee may direct a protest committee to conduct a hearing to consider redress for an appellant or other *party*.
- (c) No member of the association appeals committee shall take part in the discussion or decision on an appeal or a request for confirmation or correction to the US SAILING Appeals Committee.
- (d) The US SAILING Appeals Committee may direct an association appeals committee to consider an appeal it has refused to decide.

152nd NYYC ANNUAL REGATTA

Attachment C – Buoy Courses

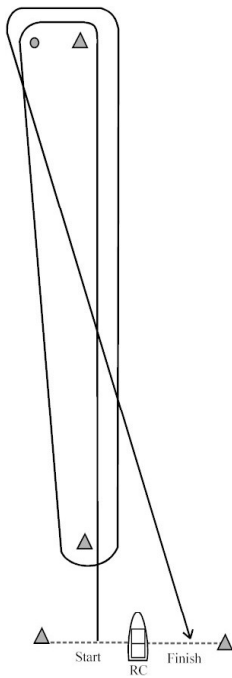

Course "W"
Even # legs

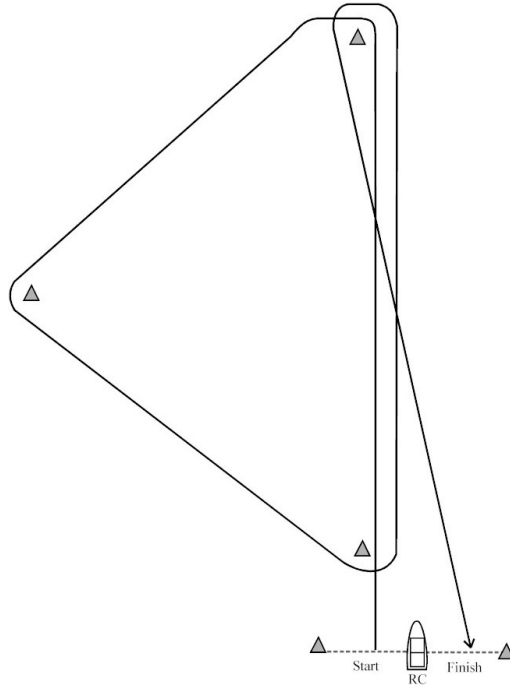

Course "K"

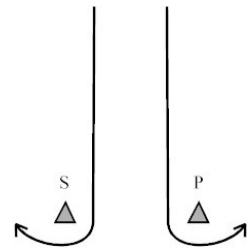

Gate Marks

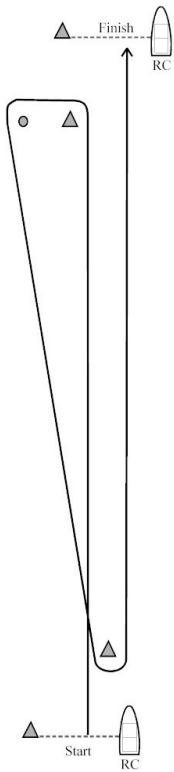

Course "W"
Odd # legs

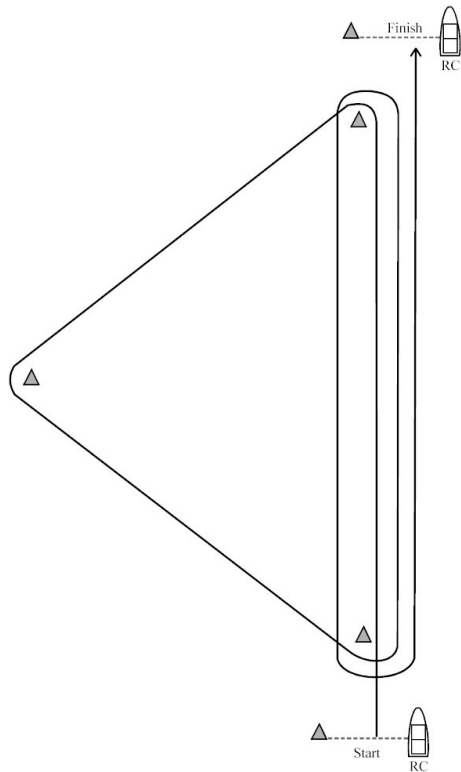

Course "O"